



IECEX Certificate of Conformity

INTERNATIONAL ELECTROTECHNICAL COMMISSION IEC Certification Scheme for Explosive Atmospheres

for rules and details of the IECEx Scheme visit www.iecex.com

Certificate No.: IECEx CQM 19.0008X

Issue No: 0

Certificate history:

Issue No. 0 (2019-03-29)

Status: **Current**

Page 1 of 3

Date of Issue: **2019-03-29**

Applicant: **Shenyang VibroTech Instruments INC**
Room 206, No. 7 Xinlong Street, HunNan New District, Shenyang City, Postal
code: 110179
China

Equipment: **Mechanical vibration switch MVS1110 Series**

Optional accessory:

Type of Protection: **Ex 'd'**

Marking:
Ex db IIC T6 Gb IP66
Tamb: -55°C ~+70°C

Approved for issue on behalf of the IECEx
Certification Body:

Ji Xiaodong

Position:

General Manager

Signature:
(for printed version)

Date:

2019-03-29

1. This certificate and schedule may only be reproduced in full.
2. This certificate is not transferable and remains the property of the issuing body.
3. The Status and authenticity of this certificate may be verified by visiting the [Official IECEx Website](http://www.iecex.com).

Certificate issued by:

China Quality Mark Certification Group Co., Ltd.
No. 33 Zengguang Road, Haidian District,
Beijing City, Postal code: 100048
China





IECEX Certificate of Conformity

Certificate No: IECEX CQM 19.0008X Issue No: 0
Date of Issue: 2019-03-29 Page 2 of 3
Manufacturer: **Shenyang VibroTech Instruments INC**
Room 206, No.7Xinlong Street, HunNan New District, Shenyang City, Postal code:110179
China

Additional Manufacturing location(s):

Shenyang VibroTech Instruments INC
Gate 17, No. 23-2, Yunfeng North Street, Tiexi District, Shenyang, Liaoning Province,
Postal code: 110021
China

This certificate is issued as verification that a sample(s), representative of production, was assessed and tested and found to comply with the IEC Standard list below and that the manufacturer's quality system, relating to the Ex products covered by this certificate, was assessed and found to comply with the IECEX Quality system requirements. This certificate is granted subject to the conditions as set out in IECEX Scheme Rules, IECEX 02 and Operational Documents as amended.

STANDARDS:

The apparatus and any acceptable variations to it specified in the schedule of this certificate and the identified documents, was found to comply with the following standards:

IEC 60079-0 : 2017 Explosive atmospheres - Part 0: Equipment - General requirements
Edition:7.0
IEC 60079-1 : 2014-06 Explosive atmospheres - Part 1: Equipment protection by flameproof enclosures "d"
Edition:7.0

*This Certificate **does not** indicate compliance with electrical safety and performance requirements other than those expressly included in the Standards listed above.*

TEST & ASSESSMENT REPORTS:

A sample(s) of the equipment listed has successfully met the examination and test requirements as recorded in

Test Report:

CN/CQM/ExTR19.0009/00

Quality Assessment Report:

CN/CQM/QAR19.0001/00



IECEX Certificate of Conformity

Certificate No: IECEx CQM 19.0008X

Issue No: 0

Date of Issue: 2019-03-29

Page 3 of 3

Schedule

EQUIPMENT:

Equipment and systems covered by this certificate are as follows:

General product information

MVS1110 Series equipments are mechanical vibration switches. The detailed model definition is specified in attachment.

There is a SPDT or DPDT micro switch inside this equipment, which is controlled by hand or one electromagnetic coil inside.

Each vibration switch has one flameproof compartment. The flameproof joint between cover and shell is a plane joint. The flameproof joint between reset button and copper sleeve is a cylindrical joint. The flameproof joint between range adjusting column and copper sleeve is a cylindrical joint. There is a threaded hole on the shell reserved for IECEx certified entry with flameproof threaded joint of 3/4"NPT, 1/2"NPT or M20×1.5.

The material of mechanical vibration switch enclosure is alloyed aluminium or stainless steel 316L. There is an internal earthing bolt and an external bolt on the enclosure.

Rating

See attachment.

SPECIFIC CONDITIONS OF USE: YES as shown below:

1. Rated ambient temperature is from -55°C to +70°C.
2. Contact the original manufacturer for information on the dimensions of the flameproof joints when repair.
3. When assembly, operation and maintenance, the operator should follow the requirements of IEC 60079-14:2007.
3. The entries intended to be installed in the reserved threaded hole should have IECEx certificate.
4. WARNING – DO NOT OPEN WHEN ENERGIZED.
5. CAUTION - USE FASTENER WITH YIELD STRESS \geq 640 MPa.

Annex:

[Attachment to IECEx CQM 19.0008X issue 0.pdf](#)



Attachment to Certificate

IECEX CQM 19.0008X issue No.:0



Applicant: Shenyang VibroTech Instruments INC

Room 206, No.7 Xinlong Street, HunNan New District, Shenyang, Liaoning Province, Postal Code:110179 China

Electrical equipment:

MECHANICAL VIBRATION SWITCH MVS1110 series

Description of equipment:

1. Model definition

MVS 1110 A B C — D E — F

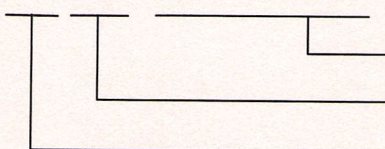

A- F definition specified in Table 1

Internal Serial Number

Abbreviation of the mechanical vibration switch

Table 1 Definition of A-F

A	Measurement rang
0	2g
1	5g
2	10g
B	contacts
1	SPDT, plating silver
2	DPDT, plating silver
3	SPDT, plating gold
4	DPDT, plating gold
C	Explosion-proof Grade
4	IECEX, Ex db IIC T6 Gb
D	Reset coil/startup delay
0	no
1	115VAC
2	230VAC
3	24VDC
4	115VDC
E	Electrical interface
1	3/4" NPT
2	M20×1.5
3	1/2" NPT
F	Materials
1	Cast aluminum (blank represents default)
2	316L



Attachment to Certificate

IECEX CQM 19.0008X issue No.:0



2. Thread hole reserved for IECEx Certified Entry

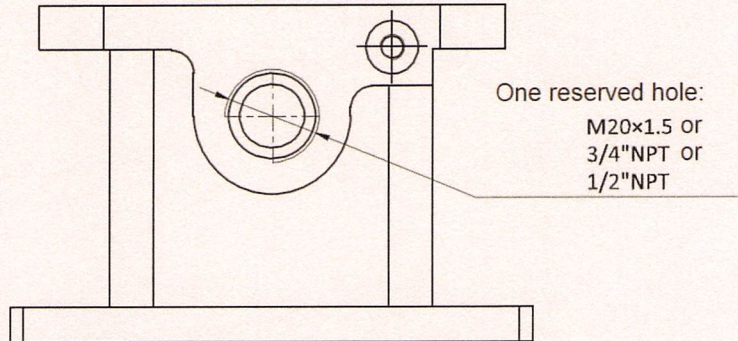

3. Rating

For MVS1110 with electromagnetic coil:

Rated voltage	Rated current	Acceleration
115Vac	1.42 A	/
230Vac	0.48 A	/
24 VDC	1.98 A	5 g
24 VDC	1.20 A	2 g
24 VDC	2.90 A	10 g
115 VDC	1.40 A	/